





# Machine Gun

Words and Music by  
Sara Bareilles

Slowly, in 2



Tell me off in a let - ter; com - plete - ly ig -  
Stand in line wast - ing all of your time just to  
Locked and load - ed, you're prac - ti - c'ly float - ing a -

more me. Get - ting high off of  
hate me. Ev - 'ry dime gone to  
way now. In your for - tress, you

Am/C  Dm7  Bb  C7sus4 

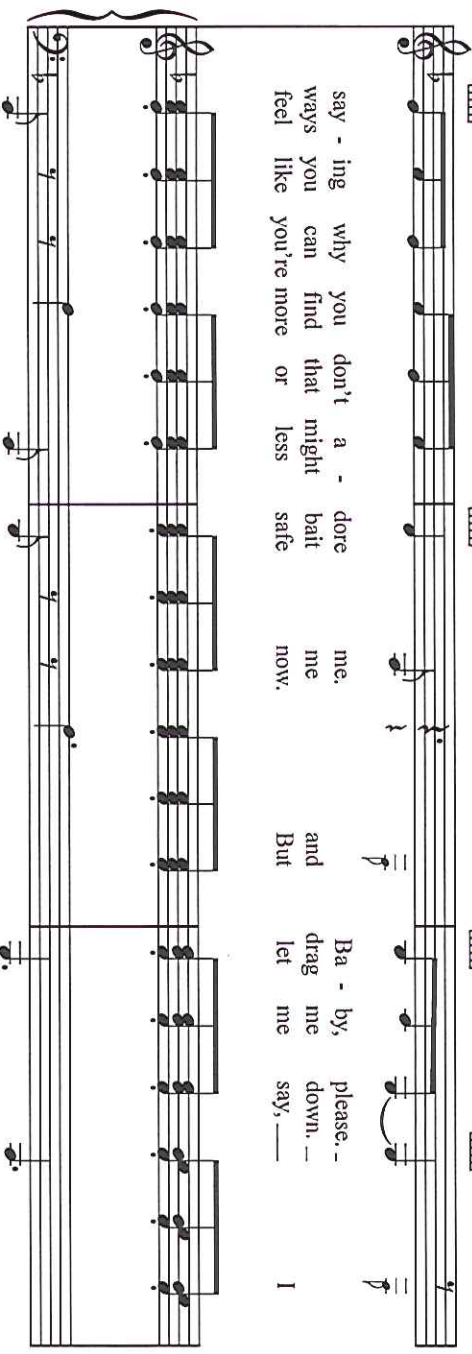

say - ing why you don't a - dore me. please. -  
 ways you can find that might bait me me down. -  
 feel like you're more or less safe now. But and drag me say, -  
 I

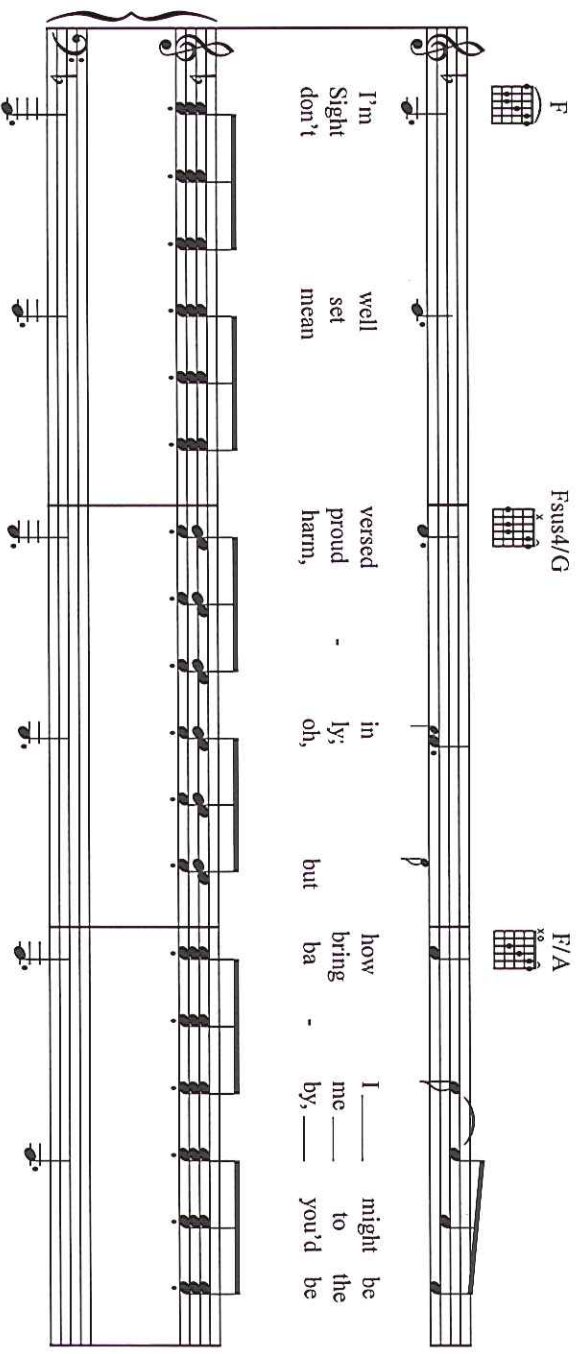

F  Fsus4/G  F/A 

I'm well versed in how I might be  
 Sigh set proud ly; oh, but bring me to the  
 don't mean harm, - in ly; oh, but ba - by, - you'd



1.  
 Bbsus2/D  F  C7sus4 

cursed, - I - - - don't - need it ar - tic - u - lat - ed.

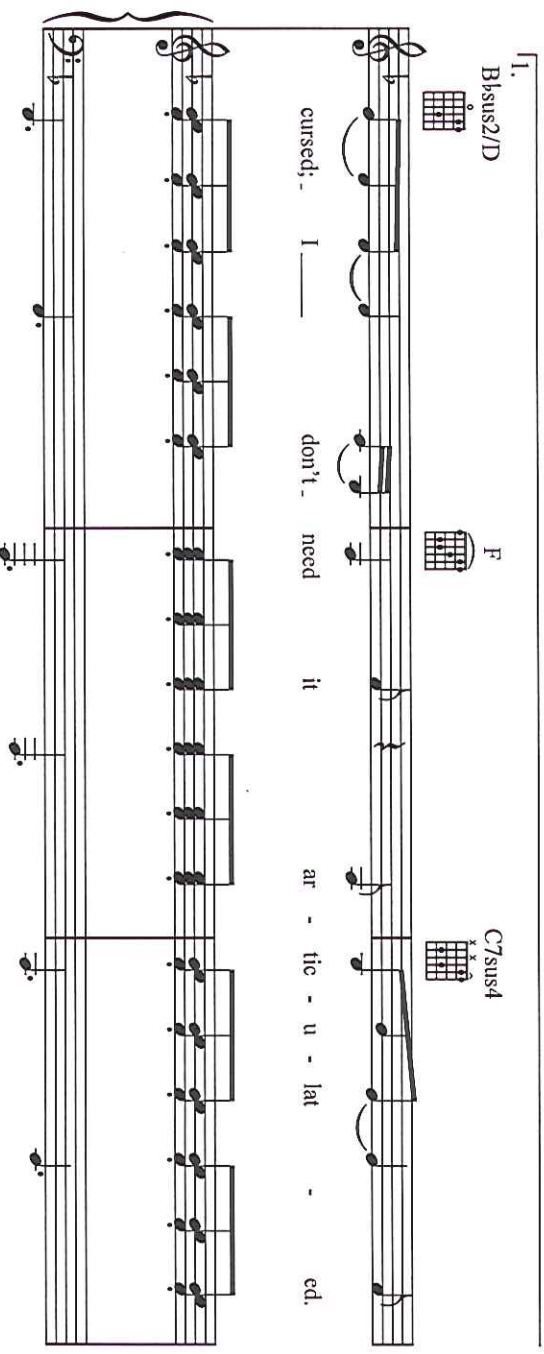

F Am/C F

|| 2.3.

Am/C Bbsus2/D F

ground, ——— see, You love to be ———  
 charm - ing ——— if you'd come un - done. —

Bbm Eb7

some - bod - y's en - e - my. ———  
 Get back where you start - ed from. ———

Ab Dbsus2 Dbsus2/Eb Eb

May - be no - bod - y loved you when you were young. —

E $\flat$ 7sus4

A $\flat$

D $\flat$ sus2

D $\flat$ sus2/E $\flat$

May - be, boy, when you cry, \_\_\_\_\_ no - bod - y

E $\flat$

E $\flat$ sus4

B $\flat$ m

ev - er comes. \_\_\_\_\_

Will you try it once?

Fm

D $\flat$

To Coda II  $\Phi$

D $\flat$ /C

D $\flat$ /B $\flat$

Give up the ma - chine gun. \_\_\_\_\_

Ma -

D $\flat$



To Coda I  $\Phi$

E $\flat$



F

chine \_\_\_\_\_ gun. \_\_\_\_\_

Yeah.

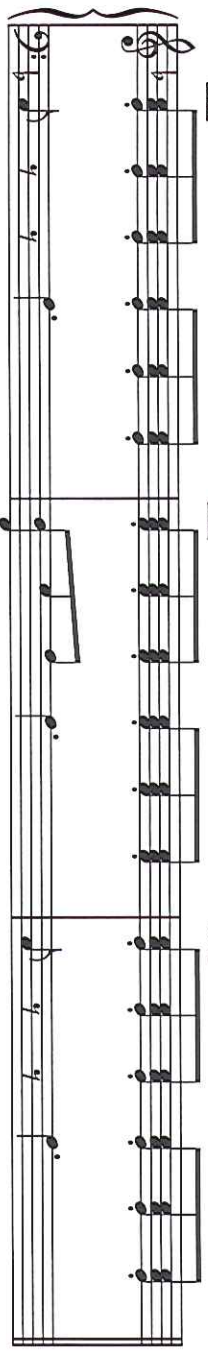
Am/C  F  Am/C  D.S.  $\text{\textcircled{8}}$  al Coda I 5





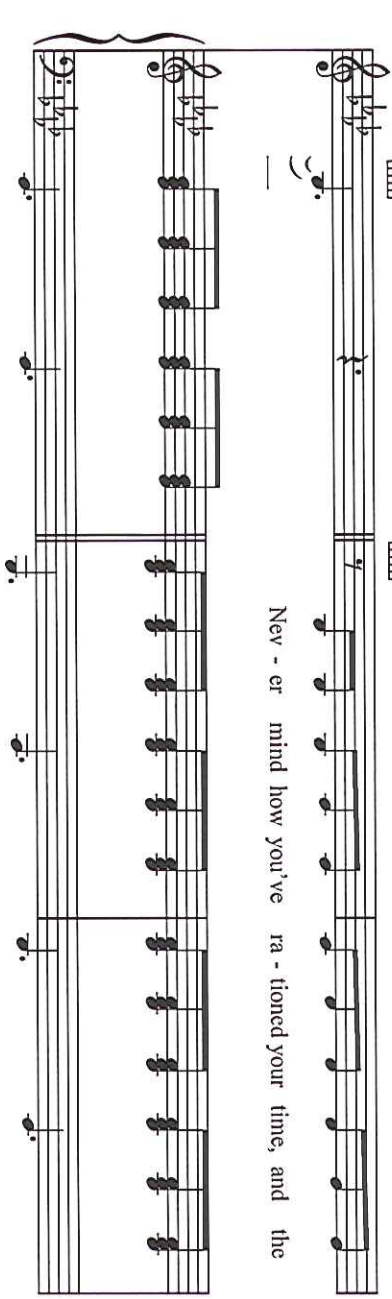

Coda I  $\text{\textcircled{0}}$  Eb  Bbm 





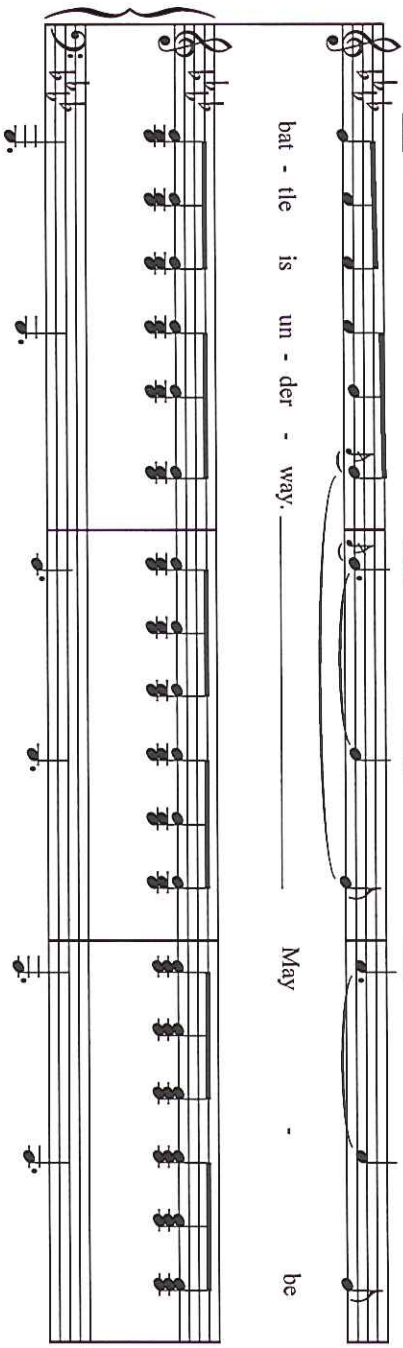

bat - tle is un - der - way. ————— May - - be

Ne - er mind how you've ra - tioned your time, and the

Eb/G  Eb  Eb/Db  Ab 



Db  Ab/C  Db/F  Db  Ab/C 

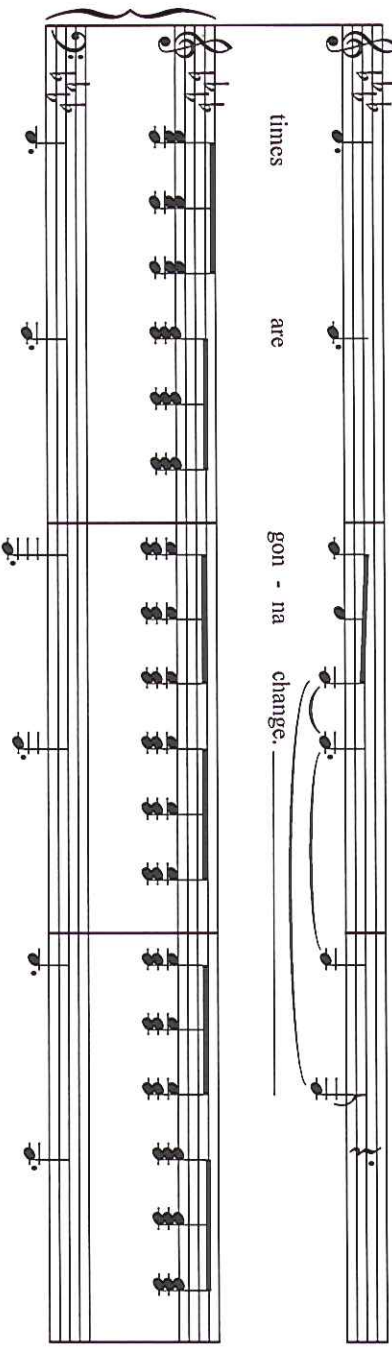

times are gon - na change. —————



Don't just hide in the si - lence be - hind what you've real - ly been try'n' to say -



Yeah, —————  
yeah. —————



What a skill, ba - by,



aim - ing to kill me with words you ——— don't

Bbm/D $\flat$



E $\flat$ 7



*D.S. al Coda II*

mean.

Musical notation for the first system, including vocal line and guitar accompaniment.

*Coda II*

D $\flat$ /C

D $\flat$ /B $\flat$

Bbm

Fm

Will you try it once?

Give up the ma -

Musical notation for the second system, including vocal line and guitar accompaniment.

D $\flat$



D $\flat$ /C



D $\flat$ /B $\flat$



Bbm



chine

gun.

Will you try it once?

Musical notation for the third system, including vocal line and guitar accompaniment.

Fm



D $\flat$



D $\flat$ /C



D $\flat$ /B $\flat$





Give up the ma - chine

gun.

Ma -

Musical notation for the fourth system, including vocal line and guitar accompaniment.

D $\flat$    $x^4$

E $\flat$    $x^6$

chine \_\_\_\_\_ gun, \_\_\_\_\_

F   $x^4$

Yeah.

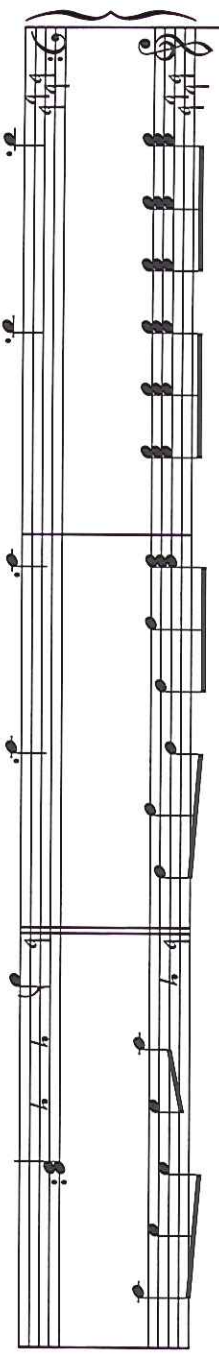



Am/C   $x^4$

F   $x^4$

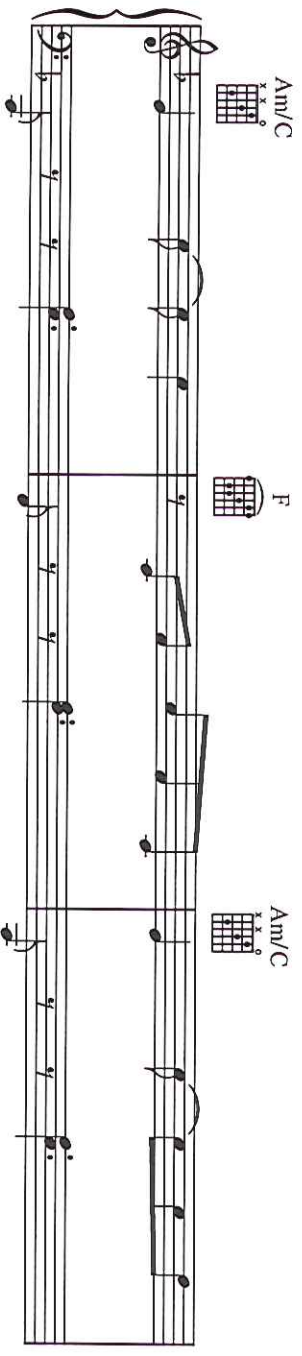
Am/C   $x^4$





F   $x^4$

Am/C   $x^4$

F   $x^4$

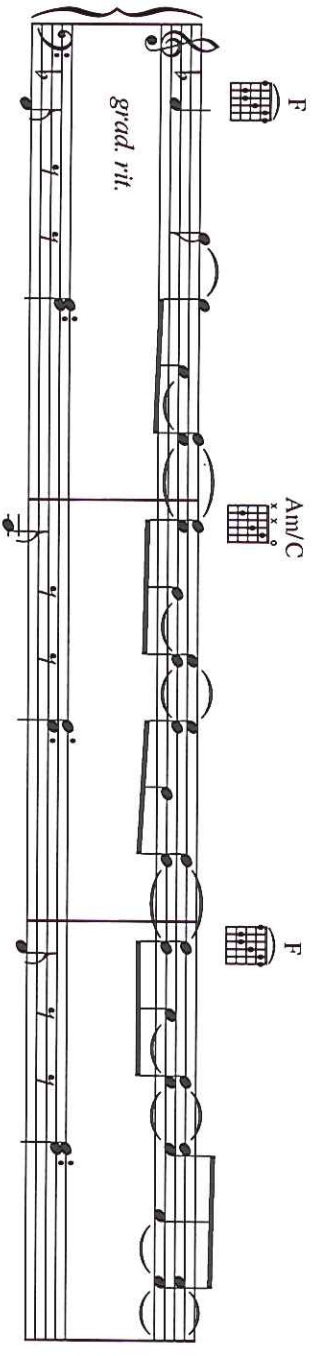
*grad rit.*



Am/C   $x^4$

F   $x^4$

*mp*

*Freely*

